



# **2015 NATIONAL BANGER SPECIFICATIONS**

## **EXCLUDING UNLIMITED CC** Please refer to separate specifications

The overriding principle of these regulations is that unless it is stated that you can do it, you must work on the principle that you CANNOT.

### **1. TYPE OF CAR PERMITTED FOR USE**

- You must use any four wheel saloon, coupe, estate car or people carrier. No SUV's or 4 x 4 vehicles allowed.
- For ease of classification weight categories taken from MOT Brake Weight Chart maybe used to determine which cars are eligible.
- (900kg - 1250kg) e.g Metro - Cavalier
- (1100kg - 1560kg) e.g. Cortina - Granada Estate

Furthermore, classifications may be done using engine cc and may include (but not exclusively) the following:

### **2 litre National Banger Events**

- ***On rear wheel drive cars the engine and gearbox can be replaced with any other 2 litre engine.***
- ***On front wheel drive cars engines can only be swapped within the Ford Mondeo model range 2 litre and below (this excludes the use of any Ford ST170 components which are not permitted in this class).***

### **Micro (under 1400cc) National Banger Events**

- ***No engine swaps are permitted.***
  - Engine mounts may be strengthened but must remain in the original place if fitted. ***One additional steel engine mounting is allowed.*** Modified engine mounts can be welded to the cross member, but must be bolted if attached to the chassis.
  - Replacement gearbox mountings must not be any wider than 6" (150mm) (front to back) and no longer than the distance between the chassis rails, and secured with two bolts.
  - No additional metal is allowed on the chassis to mount the engine, and engine mounts must not protect water outlets or distributors etc.
  - Only cars which are included on the following list can be used. For any cars which are not included please contact the relevant promoter for permission to use the car you believe meets the necessary specifications.
- |  |   |
|--|---|
| • <b>Austin</b> - A30 / A35 / A40 (Farina only NOT Somerset or Cambridge)<br>1100/1300/Allegro/Metro | • <b>Mazda</b> – 121                                  |
| • <b>Chevrolet</b> – Matiz   | • <b>Morris</b> - 1100 / 1300 / Minor                 |
| • <b>Citroen</b> - 2CV / Dyane / AX / Saxo / Visa / C1   | • <b>Nissan</b> – Micra / Pixo                        |
| • <b>Daewoo</b> – Matiz  | • <b>Peugeot</b> - 104 / 106 / 107 / 205              |
| • <b>Daihatsu</b> – Charade  | • <b>Proton</b> – Satria / Compact                    |
| • <b>Datsun</b> - 100A (Cherry)  | • <b>Renault</b> - 4 / 5 / 6 / 10 / Clio / Modus      |
| • <b>Fiat</b> - Panda / Punto / Uno / 126 / 127  | • <b>Riley</b> – Elf                                  |
| • <b>Cinquecento</b>   | • <b>Rover</b> – Metro (known as 100)                 |
| • <b>Ford</b> - Fiesta / Ka / Popular 100E / Anglia  | • <b>Skoda</b> – Favorit                              |
| • <b>Hillman</b> – Imp (derivatives of this model)   | • <b>Smart Car</b>                                    |
| • <b>Honda</b> - Civic (1st generation 1972-1979 only)   | • <b>Subaru</b> – Vivio                               |
| • <b>Hyundai</b> – i10   | • <b>Suzuki</b> – Swift / Wagon R                     |
| • <b>Kia</b> – Pride / Picanto   | • <b>Talbot</b> – Samba                               |
| • <b>Lada</b> – Samara   | • <b>Toyota</b> – Starlet / Aygo                      |
| • <b>Lancia</b> – Fulvia   | • <b>Vauxhall</b> - Nova / Corsa / HA Viva / Chevette |
| • <b>Mini</b> – Classic  | • <b>Volkswagen</b> - Polo / Beetle (Type 1) / Fox    |
|  | • <b>Wolseley</b> – Hornet                            |
|  | • <b>Yugo</b>   |

### **Van National Banger Events**

- Roll cages must be a minimum of one acrow bar up to a maximum of a full roll cage. If the single bar option is used, it must be fitted centrally behind the driver's seat, plated top and bottom, minimum four bolts per plate. A full roll cage is recommended on fibreglass bodies and flat fronted vans, so as to help protect the driver's feet. If fibreglass type body, then the door plate can be welded to the roll cage on the driver's side. The driver's seat must be secured at shoulder height to the door pillars or cage, if fitted. Each promotion may have additional regulations – please check.
- An engine guard is permitted on cam belt or forward facing distributor type engines. This is to protect the engine only and not to add strength to the van and may only be bolted to the engine. The scrutineer's decision is final.
- Vans with independent chassis, the rear end must be removed back up to the rear spring hanger, to allow the body to collapse.

- If it is not possible to fit a water tank within the National Banger rules above, the local Promoter may allow the fitment elsewhere within the car.
- Engines must be in original position.
- No air cooled 'Plant' type engines
- Roll cage may not extend beyond the front bulkhead.

### Special Meetings

Promoters may run special meetings for a certain type of vehicle e.g. 7.5 tonnes vehicles, SUV's, 4 X 4's, Reliant Robins, Coaches etc, for which rules will be issued by the Staging Promoter. Left hand drive vehicles may be permitted at the promoter's discretion – this should be checked in advance with the staging promoter.

## 2. STRIPPING & PREPARATION

- It is compulsory to remove all the interior, glass, airbags and charges, spoilers and side-skirts.
- The complete dashboard should be removed wherever possible.
- Remove all seats except the driver's which must be retained, the use of a racing seat is not allowed.
- Remove spare wheel carriers and tow bars plus **associated steelwork** if fitted.
- Original fuel tanks must be removed. If however, the tank is an integral part of the body you must remove as much as possible.
- Only the original standard steel bumper can be used (with the exception of Vectras and Mondeos noted below). If a front bumper is fitted, a maximum of three additional bolts may also be fitted to secure it in place. No wrap around bumpers allowed. Plastic bumpers must be removed.
- Vectras, Mk1 or Mk2 Mondeos must not be fitted with bumpers or steel plate.
- **All cars with aluminium bumpers must have the bumper and retaining irons removed before racing e.g. Volvo 2 series and Saab, you may fit a bumper/flat plate 100mm x 3mm in its place. This may be folded back a maximum of 3" (75mm) with a maximum of two bolts per side. The bolts must go THROUGH the chassis and not UP the chassis.**
- Later type cars with extended chassis rails e.g. Mk3 Mondeo/Focus, may also be fitted with a bumper or plate to the above rule or cut the chassis rail back to the front valance.
- Cars with no front cross members may use a Ford Galaxy people carrier front bumper or similar replacement. It is also permitted to link the chassis members with a chain.

## 3. ROLL BAR

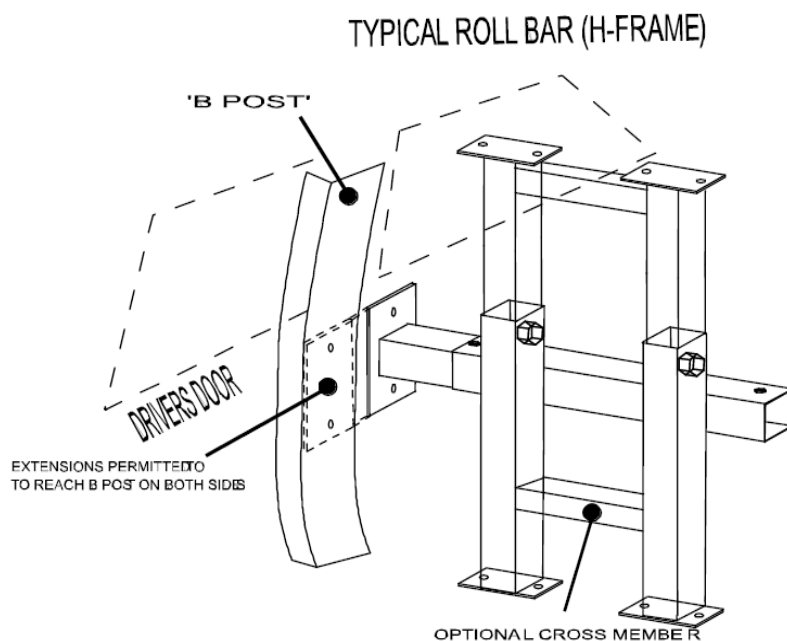

Plans Supplied by BBR Fabrication 07974 188819

- You must fit a single "hoop" roll bar in support of the door pillars, securely bolted to the roof and floor with a minimum size M12 bolt and suitable washers.
- You must have a minimum of four bolts in the top and four in the bottom, with a maximum of eight in the bottom on each side. **The maximum size of the base plate is 12" (300mm) x 9" (230mm)**
- Roll cages may be adjustable (height and width), however the use of screw adjusters i.e. acrow style, are not permitted.
- The roll cage must be fitted upright or dog-legged, but not leaning back or forward.
- It is compulsory to pad roll cages by the drivers head, the B pillar and steering columns with high density foam.
- The hoop must be one piece, or two uprights and one top bar of a welded construction. This top bar should be as shown at the top of the uprights.
- A second cross bar is compulsory, a third is optional; these must be welded or bolted to the uprights.

- **THE ROLL BAR MUST NOT HAVE ANY REAR SUPPORTS but may have extensions no further forward than the B post (see diagram) (this applies to both sides of the car). If used, it is highly recommended that this is bolted through the B post.**
- You may bolt the roll bar through both sides of the car.
- The minimum size steel for the roll bar is 2" (50mm) x 2" (50mm) RHS or tube equivalent, up to a maximum size of 4" (100mm) x 4" (100mm) ) RHS or tube equivalent. A minimum wall thickness of 3mm is required.
- Crossbars must have a 5" (125mm) square end plate fitted. This must be a minimum of 6mm thick.
- You must tie the seat at shoulder level to the roll cage or B pillar. This must be done through the seat frame and not the headrest; you may fit the 2<sup>nd</sup> cross bar in support of the seat just below the window aperture or weld a frame on the cage to support the seat at the top.

#### **4. STRENGTHENING & PREPARATION**

- **Cars that fail pre or post-race scrutineering, found to be armoured or strengthened, including engine or gearbox suspension mounts that are over the top and not rectifiable on the day, will receive an immediate ORCi ban. If the vehicle can be rectified at the track then the vehicle must race, otherwise the driver will be subject to an ORCi ban.**

##### **Doors & Door Plates**

- The driver's door may be welded, but must have no additional strengthening (this includes gussets) other than steel RHS, which is allowed in the lower window aperture of the drivers and rear driver's door, not extending further than the rear of the H frame. **Please note that this is not allowed on the passenger side.**
- A FLAT (no channel or angle) steel plate MUST be bolted over the driver's door to the following dimensions:
- **Height – minimum 10" (255mm) to a maximum of 15" (380mm)**
- **Thickness - minimum 3/8 (9mm) – 3/4" (20mm)**
- This must be fitted with a minimum of 3" (75mm) and a maximum of 6" (150mm) past the A & B pillars.
- This must be securely bolted with a minimum of four bolts.
- It is not permitted to cut slots in the driver's doorplate. Holes for bolts only.
- There must be at least one bolt through the A pillar and one through the B pillar or through the roll cage.
- **The bolt size must be at least M16 studding or bolt. M12 is acceptable on all other bolts**
- **For 2 door and pillar-less cars (no B Pillar), the door plate MUST be bolted through the roll cage.**
- Door plates cannot be joined to the water tank in any way.
- All other doors must be secured by bolting, chains or seat belt webbing. The maximum number of bolts permitted is four per door. Where plates are used to secure doors (other than the driver's door), the plates must be a maximum of 12" x 12" (300mm x 300mm) – you may use ONE additional bolt per plate to secure through the A or B Pillar, this must be a minimum size 1/4" (6mm).

##### **Driver's Floor Plate**

- A steel plate fitted to the drivers floor pan is permitted.
- It must be no thicker than 6mm, and must be bolted in only.
- Floor plates may extend up the side of the transmission tunnel, to the same height as the door sill, and up the bulkhead to within 200mm (8") of the top of the bulkhead, but the plate can only be bolted through the floor and the A-pillar only, not to the sill, tunnel or bulkhead.
- A 4" (100mm) steel plate no thicker than 6mm bolted through the A pillar to the door plate can be welded or bolted to the floor plate.

##### **Bonnet/Boot**

- The driver must present their car for pre meeting safety checks with the bonnet and bolts but they must NOT be fixed to the car.
- **Triangular corner plates or straps may be used to secure the rear of the bonnet. They must be attached to the car by bolting or tack welding to a maximum of 1" (25mm) weld with a 1" (25mm) gap in between. Plates or straps must be placed no further than 20" (500mm) across or down from the back edge and side of the bonnet. WELDING MUST NOT REACH THE 'A' PILLAR ON THE PASSENGER SIDE.**
- **Bonnets must be bolted down using a maximum of four bolts, two bolts in either side of the bonnet. Maximum height of bolt above the washer is 1 1/2" (37.5mm).**
- **Bonnets must not be moved forward or overlapped.**
- **Front bonnet bolts may go through either the slam panel, inner wings or the chassis or you may weld / bolt a piece of 2" x 2" (50mm x 50mm) metal SHS OR 3" x 3" (75mm x 75mm) metal angle to a maximum length of 3" (75mm) for the bonnet bolt to pass through.**
- **Crush tubes may be used, which must be a maximum of 2" (50mm) outside diameter steel tube, with a maximum 5mm wall thickness. If bolted, a secondary plate on the opposite side is not permitted.**
- **Rear crush tubes can be secured by either bolting or welding.**
- Maximum size of bolt or studding is 1" (25mm), including shouldering. Cam wheels must not be used as bonnet washers. Maximum size of the washer is 7" (175mm) x 5" (125mm).
- Maximum length of chain if used is 24" (60cm).

- Boot lid or rear door on estate cars may be chained or bolted. If using bolts, a maximum of four, one in each corner, a maximum size of 3/8" (9mm) maybe used, or if using chain up to 24" (60cm) in length is permitted.

### Wings

- Front wings may be folded and two additional bolts may be added to secure the wing, however this is not allowed on Vectras or Mk1 or Mk2 Mondeos.
- A maximum of two additional bolts are allowed on rear wings/wheel arches.

### General

- If the complete dashboard has been removed, then you may be required to make an additional brace to secure the steering column, however this is mandatory if the standard support is removed i.e. cross bar on a Mondeo.
- No screen bars allowed.
- You are not permitted to strengthen the gearbox tunnel.
- Expanding foam or any other material must not be used to fill chassis or door sills etc.
- Sunroof must be bolted **or welded**. If covered, the maximum thickness of flat steel plate is 1/8" (3mm), and the maximum size is 4" (100mm) larger than the sun roof opening. Cars without a sunroof may also be fitted with a roof plate - this must be no further than back than the roll cage, and must not extend beyond the edges of the roof. This plate must be a maximum of 3mm thick, and must be securely bolted or welded.
- **Any repair welding can only be made with the same gauge metal as the original part of the body or chassis being repaired (maximum of 3" (75mm) square). This can only be secured by tack welding - welding 1" (25mm) with a 1" (25mm) gap before the next weld. One plate can be used to secure the inner wing to the chassis rail. – THIS IS ONLY ON NEW CAR BUILDS.**
- **It is not permitted to panel in headlight and window apertures.**
- **It is not permitted to panel in the inside of doors and or the rear parcel shelf and these must be left as original. Drivers name visors must be at the top of the windscreen only and must not be welded in place.**  
**THIS INCLUDES CHAMPIONSHIP MEETINGS.**

### Suspension

- **You may strengthen the [TCA] Track Control Arm (the steering adjustment arm on the steering rack) by welding or sleeving.**
- **You may strengthen the standard original bottom arm, but this must remain standard in dimension.**
- **Re-positioning of the ball joint is not allowed.**
- Suspension legs may be welded to the hub.
- No additional strengthening of any other suspension parts is allowed.
- **Sub frames must not be welded in place.**

### Guards/Covers

- Where relevant, a crank sensor protector may be fitted to a maximum size of 2" x 2" (50mm x 50mm) steel angle, 4" in length (100mm), with a maximum of two bolt fixings, secured to the bell housing/engine.
- You may fit a steel plate distributor guard to the following specification.
  - Maximum area of 9" x 9" (230mm x 230mm), with a maximum thickness of 1/4" (6mm).
  - The steel plate may be bolted or braced using steel RHS, maximum 1" x 1" (25mm x 25mm) or welded TO THE ENGINE ONLY, I.E you CANNOT fit the guard to the sub-frame or gearbox and it must not be touching the water tank in any way.
- **Forward facing cam belt engines may run a cam cover, but these must be the same silhouette as the original and bolted to the original mountings. For avoidance of doubt, cam guards cannot be used where the engine does not have a cam belt. Maximum thickness of cam guard is 6mm.**

## 5. FUEL SYSTEM

- The original petrol tank must be removed and replaced with a maximum size 2-3 gallon safety tank fitted inside the car on or under the roll bar. Before fitting, the tank should be carefully checked to see that it cannot leak when inverted or on its side and the outlet must be from the top of the tank. The vent pipe from the top of the tank must be terminated below the floor level of the car.
- All fuel lines must be in good condition and securely clamped.
- With carburettor fuelled cars, **a manual shut-off tap must be fitted within reach of the driver when strapped in the car**, but with fuel injected cars, the fuel flow must be controlled by the pump cut off switch. Immersed fuel pumps are permitted.
- All fuel tanks must be of steel construction and have a metal screw top.
- A one way valve must be fitted to the breather pipe.

## 6. ELECTRICAL SYSTEM

- Batteries must be bolted or clamped in position and completely covered with rot-proof material to prevent acid leakage. Ratchet straps may be used as a secondary fixing only. Batteries must be fitted on or under the roll bar. If batteries are secured in a box the maximum dimensions are 18" x 12", 460mm x 300mm.

- Alternators, if fitted, cannot be wired to charge.
- All wiring must be fully insulated.
- Electrical starters must be fitted and in working order.
- Ignition and starting must be activated through an insulated switch, not by connecting bare wires together. A battery cut off switch **MUST** be mounted on the roll cage on the near side of the car; the switch must be wired to the earth side of the battery.
- Engines that are fitted with ignition system relying on a flywheel sensor (or similar), must not be modified to use a gear driven distributor.
- Ignition boxes on any fuel injection engine converted to carburettor are free, aftermarket products mapped to suit or modified original boxes modified are allowed. **HOWEVER THE ORCI WILL BE REVIEWING THIS RULE DURING 2015.**
- On fuel injection cars the engine management system including ignition boxes must remain as originally fitted and not re mapped.

## **7. COOLING SYSTEM**

- Only rectangular or L shaped tanks are permitted, with no braces. An L-shaped tank may extend towards the turret on one side of the engine only.
- Any modifications must be within the original bonnet outline.
- ***L shaped water tanks must not extend beyond the front of the engine block on rear wheel drive vehicles.***
- The tank must be no further forward than 2" (50mm) from the front face of the head on front wheel drive vehicles.
- The front of the engine is classed as the block not the pulleys or water pumps etc.
- These tanks must only be secured by four fixings and may not be welded into the car or connected to any door or floor plates in any way.
- Only two outlets are allowed from the water tank.
- PLEASE NOTE THAT WATER TANKS ARE FOR COOLING PURPOSES ONLY AND NOT FOR STRENGTHENING.
- The water pump may be removed and blanked off.
- Electric water pumps are allowed.
- No cutting of bulkheads allowed.
- Tanks must be non-pressurised.
- An overflow pipe, minimum size ½" (13mm), must go under the floor of the car and terminate at the back axle.
- Water outlets may be modified but not armoured.

## **8. ENGINES, GEARBOX & PROPSHAFTS**

- The engine and gearbox must be the one originally fitted to the range as manufactured except where specifically confirmed in section 18 of this rulebook.
- The external parts of the engine must remain standard.
- ***No skimming of the head more than 60 thou from standard.***
- ***No porting or gas flowing.***
- ***No removing or adding material to the ports or combustion chamber.***
- ***No ST170 or ST220 engine components are permitted.***
- ***The cylinder head and the camshaft(s) must remain standard and the Ford Zetec engine must stay on the original Ford camshafts. You may skim the head face for head gasket purposes only.***
- ***On front wheel drive gear box mounts can be modified but must occupy the original position.***
- Flywheels may be modified.
- Clutches are free.
- Prop shafts may be made and modified to use sliding components.
- Drive shafts must be standard to the car and must not be fabricated.
- No turbos or superchargers
- No dry sump systems.
- ***Bulkheads must remain original and not be cut or modified to fit an engine. You may cut a hole in the bulkhead to accommodate the wiring and fuel pipe.***
- ***Any Ford Pinto, Duratec or Zetec engine and gearbox may be used in any RWD car as long as this is no larger than the original engine cc.***
- Engine mounts may be strengthened but must remain in the original place if fitted. No additional mounts allowed. Modified engine mounts can be welded to the cross member, but must be bolted if attached to the chassis.
- The top left engine mounting on a Mondeo/Focus may have an extra engine mount fitted on the rear of the engine.
- Gearbox mountings on rear wheel drive cars must be original, and can be modified to be solid, or may have secondary fixing of a ratchet strap, or M16 studding made into a u-bolt with a flat plate as a washer maximum size 50mm wide 6mm thick, and 300mm long. No additional metal is allowed on the chassis to mount the engine, and engine mounts must not protect water outlets or distributors etc



- **External cambelt engines may have a copy of the original cambelt cover bolted in the original bolt holes of the cover to a maximum thickness of 6mm. These cannot be bolted in any other way except through the original bolt holes.**

## **9. EXHAUST & EXHAUST MANIFOLDS**

- **Standard tubular manifolds may be used, only if fitted as standard to that model e.g. Nissan Primera.**
- **Ford Mondeo MK1, Ford Mondeo MK2 models must use the standard cast manifold i.e. cannot use a 4 branch tubular manifold.**
- **No non-standard aftermarket exhaust manifolds are permitted.**
- A Ford Mondeo MK3 running the original Mk3 engine with the inlet manifold at the front, may use the standard 4 branch exhaust manifold fitted.
- In all cases the 4 branch manifolds allowed, must be genuine original manufacturers parts.
- If the original exhaust system has to be replaced, there must be at least one silencer to each exhaust pipe and they must be securely fixed after the manifold. No Cherry Bombs or straight through systems are allowed.
- The original mount must be supplemented with at least one additional fixing to secure the system to the car.
- **No car will be allowed to race without an exhaust system and all drivers must be aware that if your car appears to be too noisy by a scrutineer or the steward then you may not be permitted to race or may be black flagged.**

## **10. CARBURETTOR/INLET MANIFOLD**

- Fuel injection systems may be modified to carburettor using a manufactured or adapted inlet manifold and must run with one standard downdraft Weber type carburettor to a maximum size or equivalent 38 DGAV e.g. Pierburg, Solex, Weber – NO MULTIPLE CARB SETUPS. If the engine is manufactured in both forms as standard, inlet manifolds may be modified or self-manufactured items e.g. Cavalier with the earlier style inlet manifold.
- Carburettors may be replaced with the equivalent size Weber conversion as per specification below. Adapter plates may be fitted by bolting or welding (max size carburettor allowed is 38DGAS as fitted to the 3.0 Litre V6 or 2.8 carburettor).
- Vehicles fitted with fuel injection can be used providing they are fitted using the standard banger fuel system and the fuel pump is replaced with a standard high pressure pump, or submersible pump. Suitable high pressure fuel lines must be used between the fuel pump and the injection system.
- Cold starting devices may be removed.
- Jets may be changed.
- Replacement Spindles with standard screws may be fitted, no polishing or reproofing allowed, no modifying or enlargement of any fuel galleries allowed.
- Floats must not be modified or weighted and needle valve must remain standard size, enrichment or power valve must be fitted and working.
- Note: The Solex or Pierburg carburettor may be replaced with the equivalent size Weber conversion as above specification
- **All Weber carburettors must have a visual secondary fixing on the fuel inlet pipe.**
- Air filters may be removed or replaced by competition type.

## **11. SUSPENSION, BRAKES AND AXLES**

- Suspension components must remain standard, except where specific strengthening is allowed in section 4.
- **Spring assist rubbers are allowed.**
- **Springs may be changed but no 2¼ type competition springs.**
- **Springs may be heated or cut for lowering purposes.**
- A secondary fixing is required on coil springs that may fall out; chain or wire should be used.
- Shock absorbers must be standard type as fitted originally. No interchanging of suspension parts allowed.
- Bump stops may be removed.
- Camber must not be altered from standard, race damage must be proven and this will not be tolerated on new cars. The Scrutineers decision is FINAL.
- Bluebird or similar car may use a strap connecting the two wishbones, but this may not be connected to any other part of the car or the engine.
- The tack welding of anti-roll bar brackets is allowed.
- All suspension rubber mounted tops may be secured with a larger washer than original. These must not be welded.
- Brakes must be effective.
- Axle casings must not be welded or reinforced.

## **12. DIFFERENTIALS**

- Ratios are free but must be standard to the range.
- **Limited slip differentials (except shale see below), locked differentials, welded (except shale see below) or power-locked differentials are not allowed, even if fitted as standard or available as an optional extra to the car. However, on shale surfaces Limited Slip and welded Differentials are permitted.**

### 13. WHEELS

- **Any standard steel or alloy wheel up to 6½"J that fits without modification may be used.**
- **Cut and shut or banded wheels are not permitted.**
- **All wheel nuts must be fitted.**

### 14. TYRES

- You may only use conventional road tyres up to 205/50.
- All tyres should have a minimum durometer reading of 60, whenever tested.
- All identification markings to remain on tyres.
- Any tyre with buffed markings will not be accepted, and will be subject to disciplinary action.
- Tyre gaiters are permitted.
- No "run flat" tyres, no 1B rated 'Track-day' tyres, no Rally tyres or competition type or cut tyres.
- The ORCi reserves the right to ban any tyre make or type which give an unfair advantage.
- **No Yokohama, Avon 7.3 wide safety, town and country, Mud & Snow Type, Toyo, Goodyear Eagle F1, Kingpin Alpine Series competition type or cut tyres. Drivers should check with the Promotion concerned. PLEASE NOTE : At Startrax, Mud & Snow Type tyres MAY be allowed at certain events.**
- **In addition to the above, all 1B rated tyres as listed below will be banned from 1<sup>st</sup> May 2015. Any tyre listed below which is currently banned e.g. Goodyear Eagle F1 still cannot be used as per the 2014 rules and regulations:-**

#### AVON

- ACB 10 Sport
- CR6ZZ (Including Sport)
- Turbospeed CR28 Sport
- CR500
- ZZR

#### BRIDGESTONE

- Potenza S007 RFT

#### CONTINENTAL

- ContiForce Contact

#### DMACK

- Trackday

#### DUNLOP

- Formula R D83J
- Formula R D84J
- Formula R D93J
- Direzza 02G
- Direzza 03G
- CR 311
- Sport Maxx Race
- SP Sport R7

#### FEDERAL

- 595 EVO
- 595 RSR
- FZ 201

#### GOODYEAR

- EAGLE F1

#### HANKOOK

- Z209
- Z210

#### KUMHO

- Ecsta V700 (inc V78)
- Ecsta V70A
- Ecsta TW01
- Ecsta TW02
- Ecsta C03

#### MARANGONI

- Zeta Linea Sport

#### MAXXIS

- Maz1 Drift

#### MAXSPORT

- RB4 Intermediate
- RB5

#### MICHELIN

- Pilot Sport Cup
- Pilot Sport Cup 2
- TB 15
- TB 15 (f & r)

#### NANGKANG

- NS-2R

#### PIRELLI

- P Zero Trofeo
- P Zero C
- CA67
- CF67
- P Zero Corsa
- P7 Corsa Classic
- P Zeri Torfeo R12

#### SILVERSTONE

- FTZ Sport RR
- FTZ Wet Tyre
- S575
- S585

#### TOYO

- R888
- R1-R

#### YOKOHAMA

- All Tyres

### 15. SAFETY EQUIPMENT

- **Flame retardant racing suits are compulsory. Neck braces are recommended. Fireproof Balaclavas are MANDATORY. Fireproof gloves are MANDATORY and must be marked appropriately.**
- A full shoulder-type safety harness as approved by ORCi for Bangers with lap-straps must be fitted and bolted to the floor.
- A minimum of a four point buckle fixing must be used with a minimum of 3 floor fixings. A secure part of the floor or cage (including the seat bar), are recommended anchor points.
- A suitable head restraint must be fitted to the roll cage or seat. It is compulsory to pad roll cages by the drivers head including the B pillar and steering columns must also be padded with high density foam.
- A 1Kg Dry Powder Gauge Fire Extinguisher may be fitted, this should be in a tube with a spring top and should be within easy reach of the driver. Old type BCF (green) type extinguishers are not allowed. All tow vehicles, must carry a minimum of a 2kg fire extinguisher dry powder or gas, which must be within easy reach of the driver and mechanics at all times, especially when refuelling.

- Helmets must be of a minimum standard as directed by British Oval Racing Safety Executive (B.O.R.S.E). These are, FIA8860-2004, Snell SA2005, Snell SA2010, SFI Foundation 31.1A, SFI Foundation 31.2A. The E2205 European standard helmet may be used in Fibreglass, Carbon or Tri-Composite form only i.e. **NO POLYCARBONATE helmets are allowed.** It is important that the helmet fits the driver correctly. Shatterproof goggles/visors must be worn although tinted visors are not advisable. Your helmet must display the current ORCi (ORC15) sticker.
- On wet meetings waterproofs may be worn as overgarments.
- The driver's seat must be secured and supported to the roll cage at shoulder level by bolting or tying.
- The 2<sup>nd</sup> roll cage cross brace may be used to support the seat, but it must be set below the bottom of the window aperture or you may construct and weld a frame on to the cage to support the seat.
- The driver's seat must be a standard production seat, not a racing seat.

## **16. NUMBERS**

- You must fit a fin plate to the roof of your car, minimum size 18" x 12" (460mm x 300mm) and a maximum size of 20" x 15" (510mm x 380mm).
- Your number must be either white on a black background or black on a white background, no other colours allowed, **any other writing allowed must not interfere with the numbers**, which must be minimum size 9" (230mm) high x 1½" (40mm) wide. If your number is not to the above specification, you may not be lap scored.

## **17. ROOF GRADES**

- If applicable to the Promotion you race for, your grade colour must be painted on the whole roof of your car.

## **18. SUPPLEMENTARY RULES (For Special Meetings)**

- Your promoter will state either via the fixture list or special entry form at which meetings this rule can be used and therefore cannot be used by a driver regardless of type of car at a normal meeting!!

## **19. FINAL PREPARATION**

- ~~The external painting of the car should be in bright colours. Any colour schemes are permitted.~~
- Rusty or dirty vehicles will not be allowed out onto the circuit.
- Rude or provocative slogans are not allowed.
- In addition to the car construction rules, all cars presented at scrutineering must be considered safe and not unsightly.
- **New under sealing of the underside of the car is strictly forbidden.**

## **GENERAL BANGER RACING RULES**

1. All flag signals must be obeyed immediately.
2. Drivers who appear to have indulged in the intake of alcohol or drugs will be excluded from racing. Smoking is not permitted in cars, on track or in the pits at any time.
3. No passengers are allowed in the car. The driver may only travel on the car on a parade or lap of honour.
4. Banger racing is a full contact sport - drivers can race to win or attempt to win by stopping the opposition.

The Steward's interpretations and decisions on these rules are FINAL.

All heats, consolations and finals must be in one direction only. Certain Promotions allow turning around on the bends, however this does not allow a driver to drive the wrong way down the straights. It is the driver's responsibility to check with the staging Promoter exactly what rules apply at any particular meeting.

Drivers must not attack any car on the infield/safety area, or attack from the infield/safety area. An infield hit is defined when the whole car being hit is on the infield, i.e. if one wheel is still on the track, then hitting this car would be a legal hit. Again, the Stewards decision is final on this. Any serious breaches of the infield safety area rule will carry an automatic 3 month ORCi ban.

Drivers must not attack any cars after the red flag or if the stationary yellow is displayed above a car. Drivers must not attack an empty or overturned car. Any damaging collision on the driver's side between the centre of the front wheel and centre of the rear wheel will result in a penalty.

**T-boning cars which are against or close to the barrier with excessive force is not allowed. It is also not permitted to t-bone a car which is close enough to the barrier to mean that significant impact with the barrier is inevitable after the hit. Even where cars are not against or near the barrier, the Steward may**



**still consider a hard t-bone anywhere on the circuit to be excessive, and may take the appropriate action to discipline the driver. The penalty for a T-boning offence as detailed above will be 3 months.**

Dangerous and/or irresponsible driving as deemed by the Steward will incur a minimum of three months ORCi ban. For avoidance of doubt, length of the straight t-bones is considered dangerous and/or irresponsible driving.

For further guidance, the following examples may also be considered as dangerous and/or irresponsible driving at the discretion of the Steward:

- a) Attacking a car which has been stationary for what the Steward determines to be a significant length of time.
- b) Attacking a car which is clearly already crippled.

Please note that repeat offences will carry additional penalties where the current ban will be double the previous ban. This means that a 2<sup>nd</sup> offence of a 3 month ban as noted above will be 6 months and then a further offence would double again to 12 months.

Using the infield or safety area in any way so as to gain an advantage is also an offence and can be punished as so by the Steward.

5. Demolition type events. Any race where the nature of the event is to stop the opposition to win the following rules apply attacking from the opposition direction is permitted providing the attack is from the outside of the track (fence side). You are also allowed to wait for car or attack any part of the car except the driver area, which is considered to be from the centre of the front wheel to the centre of the rear door driver's side.
6. Demolition Derby rules may only be used when the staging promoter declares by way of drivers briefing, letter or notice in the programme that these rules apply.
7. Drivers who abandon their car during a race while a race is in progress must retire to a recognised safety area.
8. It is an offence to put or attempt to put an overturned car back onto its wheels during a race, drivers are not allowed to re-enter a car once they have left it. Repairs are not allowed on the circuit and car must not be pushed or handled in any way during a race.
9. Team tactics in an individual event may be subject to penalty. The decision of the steward will be final.
10. **A driver will be held responsible for his or her mechanics or helpers at all times.** Drivers will be bound by the decision of the officials in all matters (these two items are a condition of booking).
11. Drivers must bring his or her log book every time he or she races.
12. It is an offence for two drivers to share a car at the same meeting; you may only race one car at a meeting unless the promotion allows it as an option for special events, and with specific permission.
13. All cars, trim, glass and wheels must be removed from the stadium directly after the meeting.
14. In all events the racing must be on track indicated, drivers who try to gain advantage by corner cutting will be penalised or disqualified. Also drivers who continue to drive on and off the safety area will be disqualified.
15. Drivers must comply with any reasonable instruction given by an official of the meeting, failure to do so will result in a penalty or disqualification.
16. Mechanics are not allowed onto the circuit or to repair any competing car. Mechanics are allowed onto the track by invitation of the Clerk of the Course or the Racing Manager only to take part in parades or lap of honour for trophy winners.

## **REVISED RULES FOR 2015 IN BOLD/ITALIC PRINT**

**ITEMS MARKED ~~STRIKETHROUGH~~ ARE NO LONGER ALLOWED**

**2015 National Banger Technical Specifications, Issue 3, Dated 3<sup>RD</sup> February 2015**

**These rules are valid from 1<sup>st</sup> March 2015 – 28<sup>th</sup> February 2016.**